



Production Table & Sheeter / Moulder

**Models
SM220-9 & SM224-9**

We Service What We Sell!

P.O. Box 188
808 N. 2nd Ave. • Rock Rapids, IA 51246
712/472-3734 800/346-5749
Fax: 712/472-2203

LVO Sheeter with moulding assembly

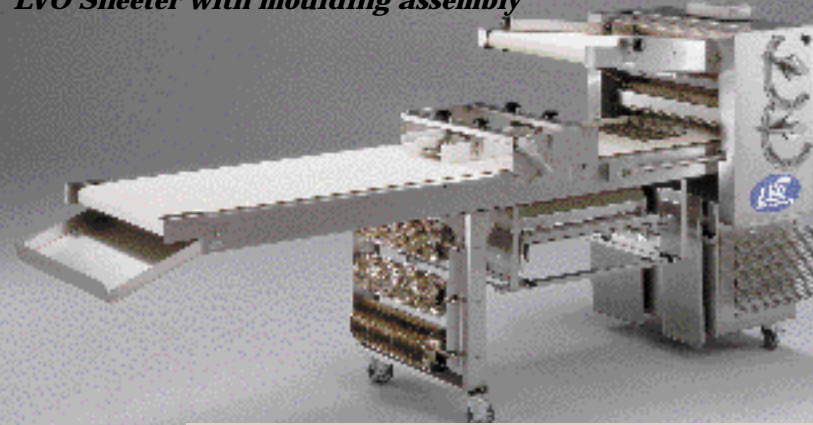

LVO Sheeter with cutter assembly

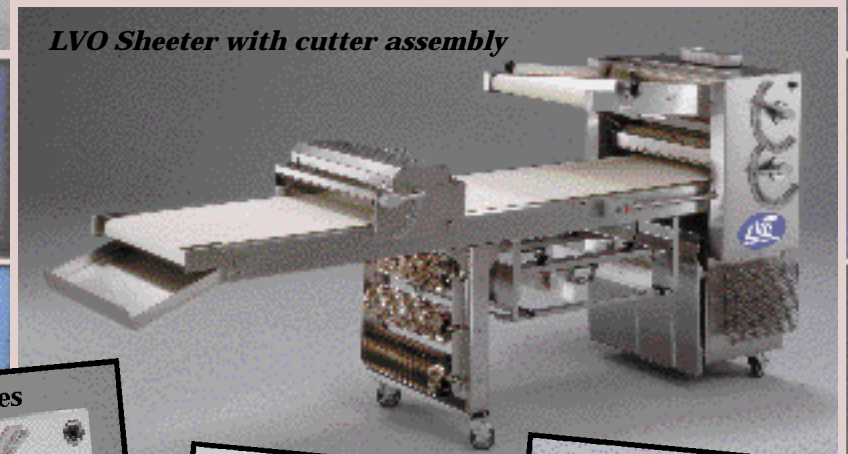

Adjusting Handles



Moulding Assembly

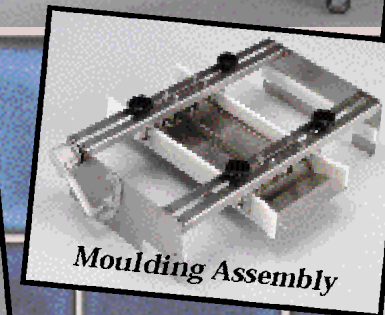

Cutter Assembly

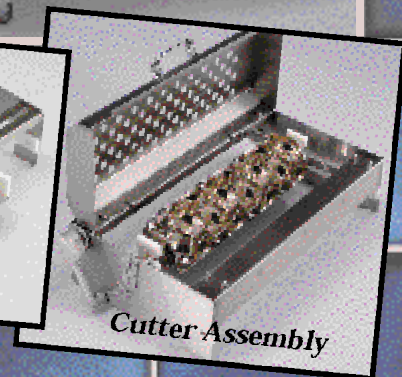

Greater Automation means greater profits, with the LVO Production Table & Sheeter / Moulder

Dimensions & Specifications – Model SM220-9 or SM224-9

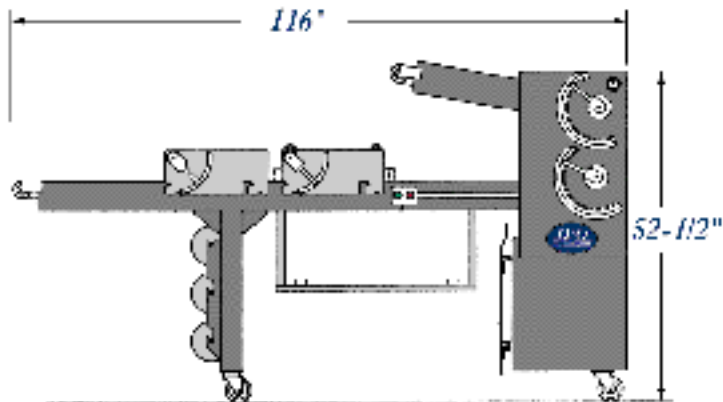
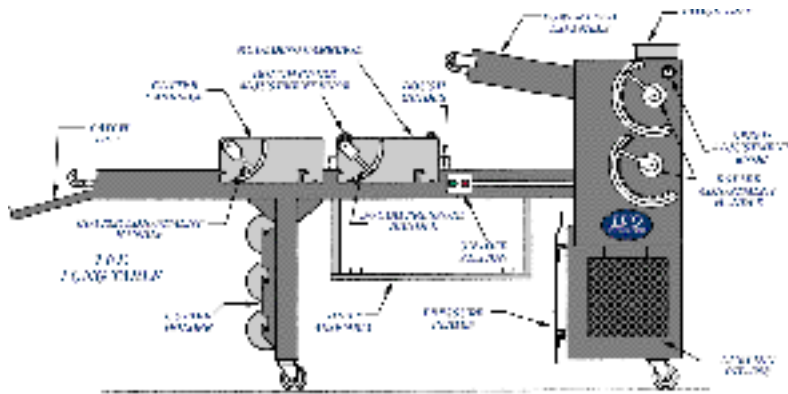

Double Feed	Overall Length	Overall Width	Overall Height
SM-220-9	116"	31-1/4"	55"
SM-224-9	116"	35-1/4"	55"

The LVO Production Table and Sheeter / Moulder combines the features of a Production Table with that of a Bread Moulder into one compact, high efficiency machine. The infeed conveyor belt carries the dough to the sheeting rollers where it is sheeted in two gradual stages.

For Bread Moulding, the dough passes to the heavy duty moulding assembly to make a variety of breads, hot dog rolls and bread sticks. Two curling chains and three pressure plates are standard equipment.

When used as a Donut Production Table for yeast fried goods, the dough is sheeted and cut with cutters automatically and uniformly. Rotary cutters are available for donuts, bismarks, long johns, croissants and turnovers. You can also sheet basic sweet dough, danish and puff pastry.

FEATURES:

- Heavy Duty Stainless Steel Construction.
- Ease of clean-up promotes a sanitary environment.
- Polyethylene dough guides, adjustable.
- Two sets of cast nylon rollers - positive adjustment.
- Nylon scrapers - easily removed for cleaning, no tools required.
- Electronic Speed Control.
- 2 - ply polyester belt.
- Three On/Off stations located on either side of machine.
- 20' electrical cord.
- Moulding Assembly removable when not in use.
- Cutter Storage Hanger for each cutter.

SPECIFICATIONS:

- Four 4" Dia. Casters - all locking type
- 1 HP Motor, 115V, 60 Cycle, 1 Phase, 10 Amps.
- Sealed Bearings throughout, no greasing necessary.
- Equipped with Automatic Roller Safety Switch - Lift bar and motor shuts off.
- Weight - approximately 960 lbs.

OPTIONS:

- 14", 16", 18", 20", or 22" Pressure Plate
- Custom table lengths.

DIMENSIONS:

- Belt Width - 20" or 24".
- Table Width - 23" or 27".
- Moulder Overall Width - 31" or 35"
- Height - 55", Length - 116"



LVO MANUFACTURING INC., Rock Rapids, Iowa 51246
712/472-3734 Fax: 712/472-2203
TOLL FREE 1-800-346-5749