



Sheeter/Moulders, Production Tables, & Conveyors



Whether you are looking to do sheeting, bread moulding, or dough cutting, the LVO sheeter line has the machine you need. With a compact simple design, even the most inexperienced employees can sheet dough in seconds. With different attachments available for moulding or cutting, making bread loaves, donuts, croissants, turnovers, and other pastries becomes automatic and uniform.



SM20/SM24 Sheeter/Moulder

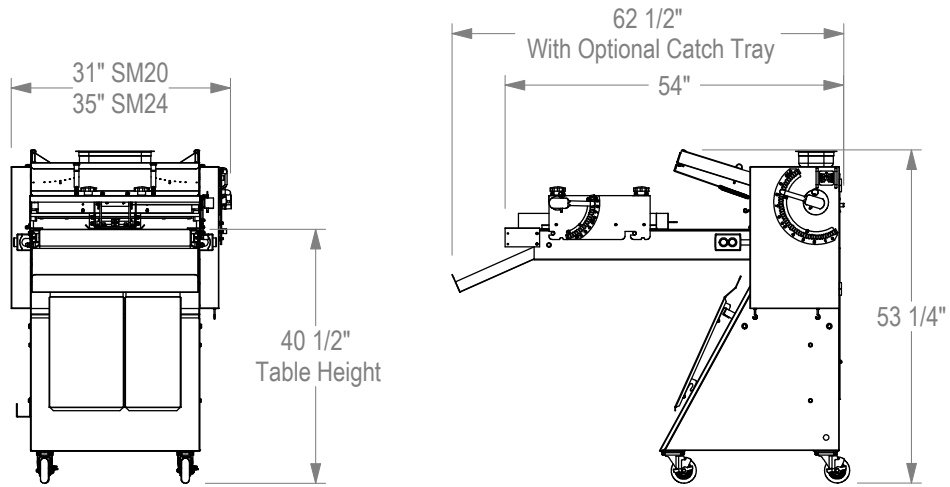

SM124 Sheeter/Moulder

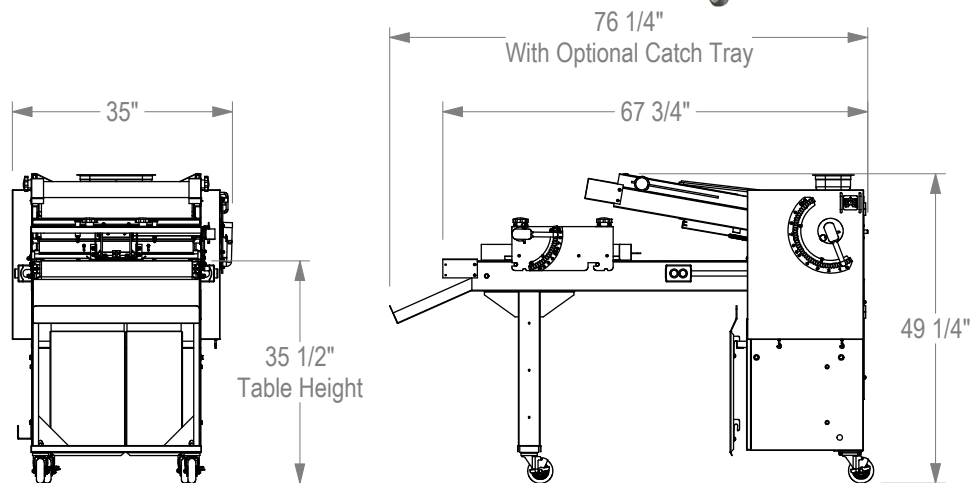

SM224 Production Table

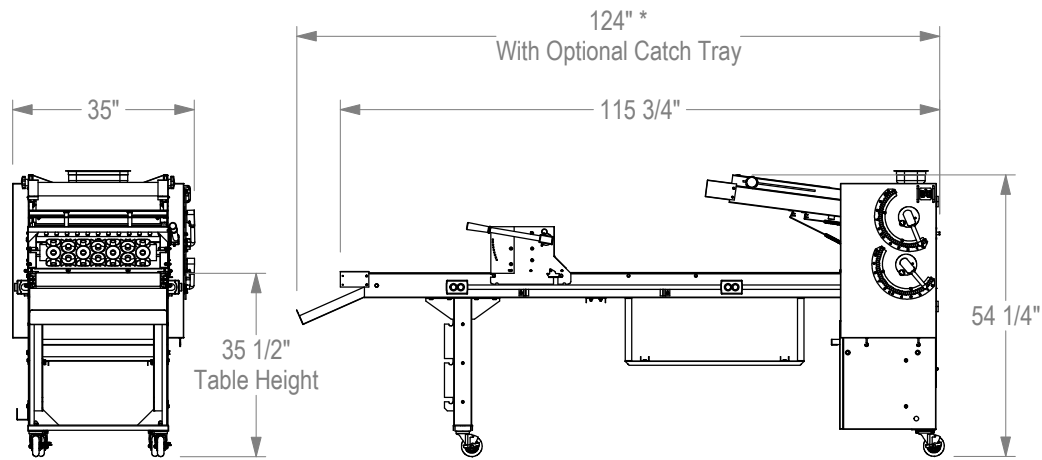

CT24 Conveyor Table

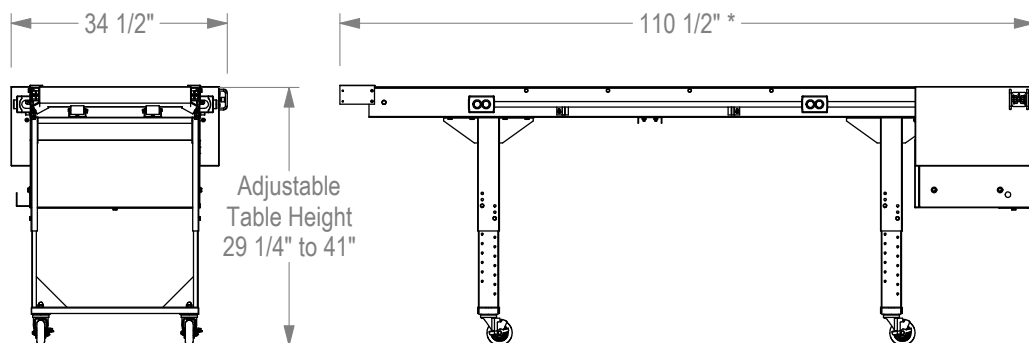

*110 1/2" Dimension for 9ft Table

Available Carriages:

Moulding Carriage

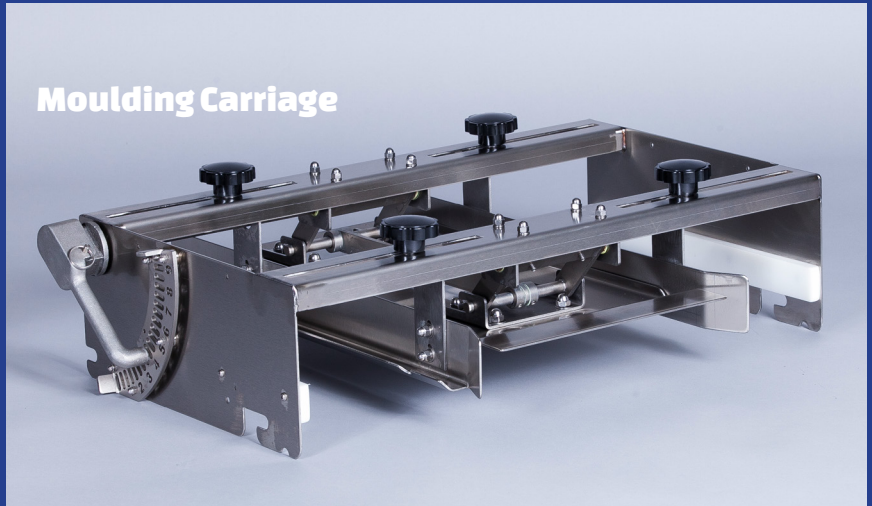

Cutter Carriage



Model:	SM20	SM24	SM124	SM224	CT24
Machine Type:	Sheeter/Moulder			Production Table	Conveyor Table
Conveyor Belt Width: (Inches)	20	24			
Table Length: (Feet)	4		5	6, 9, 12, 15, or 18	9,12,15, or 18
Number of Dough Roller Sets: (Two Rollers per Set)		1		2	0
Motor Size: (Hp)		¾		1	¾
Available Carriages:	Moulding			Moulding, Cutter	Cutter
Infeed Type:	Manual		Power		N/A
ETL Electrical Listed: (115V - US & Canada)	Yes				
ETL Sanitation Listed:	Yes			Yes - 6ft & 9ft Table	Yes - 9ft Table

All Models Available in Either Right Hand or Left Hand Control

Because of continuous improvements, specifications may change without notice. Contact manufacturer for current information.



LVO Manufacturing, Inc.

PO Box 188 • 808 North 2nd Avenue East • Rock Rapids, Iowa 51246

(800) 346-5749 • www.lvomfg.com