



# Model FL10

## Front Load Pan Washer



The LVO FL10 front load pan washer is capable of washing up to 100 pans per hour, the LVO FL10 cleans your pots, pans, bowls, or utensils with a powerful, high pressure wash. With a 7 ½ Horsepower pump and brass wash hubs, the two rotating stainless steel spray arms blast away soil for greater cleanliness.

Easy to load and operate, the front load design allows for greater access to the wash chamber, while at the same time minimizing the amount of floor space required.



## Standard Available Racks:

Sheet Pan Rack

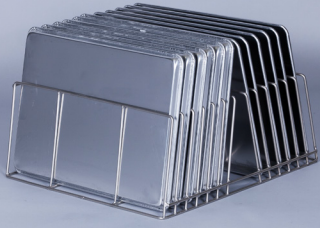

Cake Pan Rack



Utensil Basket

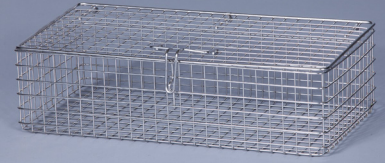

## FL10 Specs:

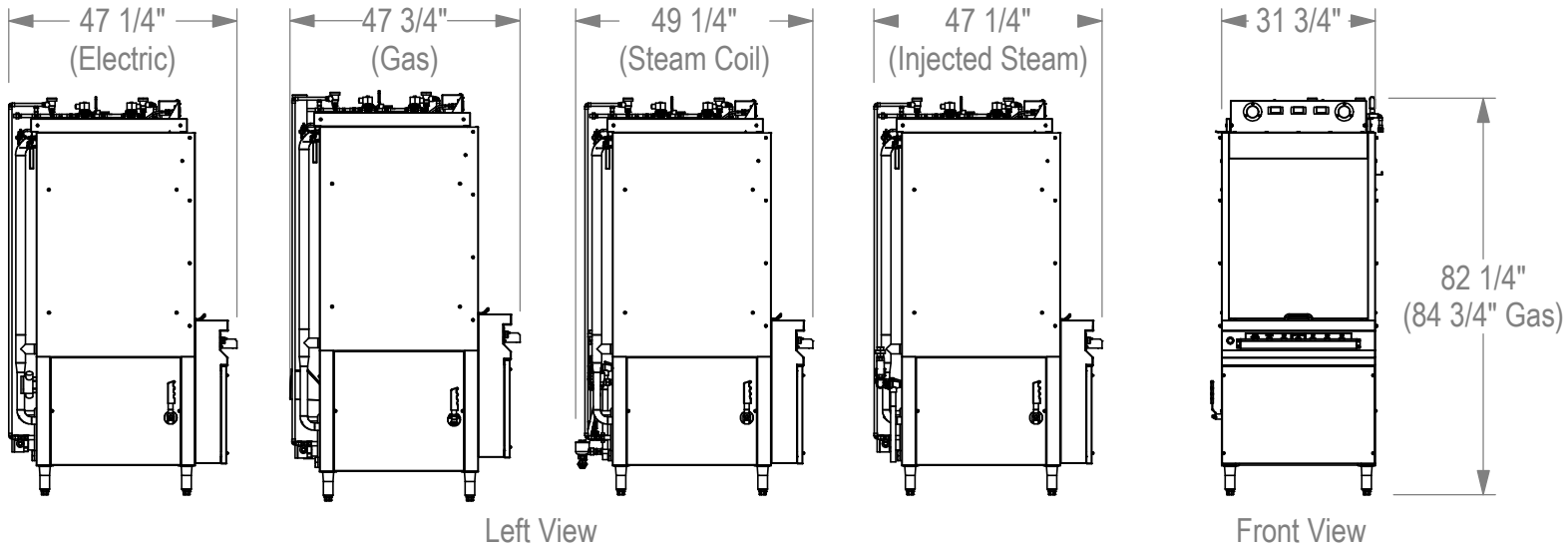

**Wash Capacity:** 10 Sheet Pans

**Standard Voltages:** 208, 230, or 460 Volt, 3 Phase, 60 Hertz

**Wash Tank:** Electric, Gas, Steam Coil, or Injected Steam Heat

**Wash Chamber Dimensions:** 28 3/4"W x 30 1/4"H x 29 3/4"L

**Height with Door Open:** 103 1/4" (105 3/4" for Gas Heated Machines)

**Agency Listings (US & Canada):** ETL (Electrical) and NSF (Sanitation)

Because of continuous improvements, specifications may change without notice. Contact manufacturer for current information.



**LVO Manufacturing, Inc.**

PO Box 188 • 808 North 2nd Avenue East • Rock Rapids, Iowa 51246

(800) 346-5749 • [www.lvomfg.com](http://www.lvomfg.com)