



LVO Manufacturing, Inc.



SM24 Sheeter/Moulder
Owner's Manual



LVO Manufacturing, Inc.

808 N. 2nd Avenue E., P.O. Box 188

Rock Rapids, IA 51246

www.lvomfg.com

(712) 472-3734

1-800-346-5749 Fax (712) 472-2203

Warranty

LVO Manufacturing Inc. warrants equipment manufactured by it to be free from defects in material and workmanship for a period of one (1) year from date of delivery except as noted below.

LVO will **not** be held responsible for damage or unsatisfactory performance due to negligence, accident, alteration, unauthorized repair, improper installation or startup (see owner's manual), improper application, or improper maintenance (see owner's manual).

Parts found, on factory inspection, to be defective in workmanship or materials during the warranty period will be replaced (parts and labor, not overtime), provided the Buyer returns the defective parts to LVO Manufacturing Inc. within 30 days, transportation prepaid. LVO Manufacturing Inc. will pay UPS 2nd Day Air shipping charges for parts (with the exception of excessively large or heavy items) covered on warranty if the machine is not operational.

LVO Manufacturing Inc. reserves the right to make changes in design and construction of its products without imposing any obligation upon itself toward products previously manufactured.

This warranty is in lieu of any other warranties, expressed or implied, made on the part of LVO Manufacturing Inc. who does not accept responsibility to any purchaser of its products for any representation or warranty made by dealers or salespersons beyond those herein expressed including any implied warranties of merchantability or fitness for a particular purpose.

Warranty Procedure

- 1) Locate and record the 12 digit serial number located on the side of the Sheeter/Moulder.
- 2) Gather as much information about the problem as possible.
- 3) Call LVO Manufacturing Inc. at 1-800-346-5749 and request technical service. Prior to performing any warranty work, you must call the factory for a warranty authorization number (WA-____). This warranty authorization number must be on every invoice we receive for services rendered on the machine. Without this authorization number the invoice will not be paid. The warranty number must also be included with the defective part returned.**



LVO Manufacturing, Inc.

808 N. 2nd Avenue E., P.O. Box 188

Rock Rapids, IA 51246

www.lvomfg.com

(712) 472-3734

1-800-346-5749

Fax (712) 472-2203

Table of Contents

Warranty.....	2
Table of Contents	3
SM20/SM24 Specifications	4
Warnings & Cautions	4
Safety Features	4
Introduction	5
Operation of Machine	6
Operational Tips.....	8
Scheduled Maintenance	9
Cleaning Instructions	10
Parts List	11
Drawings:	
(Drawing scales are approximate)	
General View	14
Two View – Informative	15
Left Side View	16
Electrical Schematic.....	17



LVO Manufacturing, Inc.

808 N. 2nd Avenue E., P.O. Box 188

Rock Rapids, IA 51246

www.lvomfg.com

(712) 472-3734

1-800-346-5749 Fax (712) 472-2203

SM20/SM24 Specifications

Overall Dimensions

Width: SM20 – 31”

Width: SM24 – 35”

Height – 53 ¼”

Table Height – 40 ½”

Depth (Standard 4’ Table) – 54” (62 ½” with Catch Tray)

Electrical Information

	115 Volt	230 Volt
Full Load Amps	7.5	3.8

Warnings & Cautions

General Warnings and Cautions:

1. Service work on the machine should be done by either a factory representative or qualified local service company. **Contact the factory if the machine is under warranty.**
2. Failure to follow the cleaning guidelines described in this manual will damage the machine and will void the warranty.

Safety Features

This machine is equipped with several safety features.



Warning: Do not operate this machine without all of these safety features installed and operational.

All of the features listed here are shown on the General View in the drawings section.

1. Front Belt Roller Finger Guard Prevents unintentional insertion of fingers into the gap between the front roller and the conveyor belt.
2. Dough Roller Safety Guard When guard is lifted, power is disconnected, shutting off Sheeter/Moulder. The machine is designed not to restart until the guard is closed and the Start Button is pushed.
3. Chain Guard Cover When cover is opened, power is disconnected, shutting off Sheeter/Moulder. The machine is designed not to restart until the cover is closed and the Start Button is pushed.
4. Rear Cover When cover is opened, the machine will stop. The machine is designed not to restart until the cover is closed and the Start Button is pushed.



CAUTION: Before doing any service work on this machine, be sure it is unplugged.



LVO Manufacturing, Inc.

808 N. 2nd Avenue E., P.O. Box 188

Rock Rapids, IA 51246

www.lvomfg.com

(712) 472-3734

1-800-346-5749

Fax (712) 472-2203

Introduction

This manual should be read and understood by everyone involved with the installation and operation of the Sheeter/Moulder. Keep this manual in a safe place for future reference. Extra copies or replacement copies can be purchased from the manufacturer.

Service work on the machine should be done by either a factory representative or qualified local service company. **Contact the factory if the machine is under warranty.**

The LVO Sheeter is designed for use in bakeries and restaurants to sheet and mould dough for bread loaves, hot dog buns, hoagies, pie crust, and pastries. LVO Sheeters are constructed from stainless steel with two 4" dough rollers made from FDA approved materials. The control system is assembled with UL approved components housed in the rear of the machine.

The LVO Sheeter can be used for both sheeting dough flat for use in pie crust and various pastries or, by attaching the moulding carriage, for moulding bread loaves and buns.

In addition, the LVO Sheeter/Moulder is equipped with a variable speed drive. This lets the operator change the speed of the machine up or down depending on their own level of experience or type of dough being used. This increases the machine's versatility, allowing it to be used for a wide range of products and operators.



LVO Manufacturing, Inc.

808 N. 2nd Avenue E., P.O. Box 188

Rock Rapids, IA 51246

www.lvomfg.com

(712) 472-3734

1-800-346-5749 Fax (712) 472-2203

Operation of Machine

General Operation

1. Position moulding carriage onto the conveyor table carriage pins, making sure adjustment handle is on the same side as the roller adjustment handle. There are two sets of carriage notches; one to lock the carriage in place while in use, and a second smaller set to raise the carriage to change the pressure plate.
2. Select the proper pressure plate (example: 6" for hot dog buns, 9" for hoagies, 12" for bread loaves, etc.). Position the pressure plate on the moulding carriage linkage with the approach/rise toward the machine sheeting rollers. Adjust plastic moulding carriage dough guides next to pressure plate.
3. For moulding, place curling chain rings (light or heavy depending on product type or weight) onto hooks on the front scrapper under infeed chute.
4. Position carriage adjustment handle to desired setting; lower for lighter weight, higher for heavier weight products.
5. Adjust infeed chute guides so that the dough enters at the middle of the rollers.
6. Set roller adjustment handle to desired thickness. The position of the handle will vary with the product type, and multiple passes may be necessary depending on the product type and stiffness.
7. Dust the sheeting rollers with flour to prevent the dough from sticking to the rollers. A flour tray is supplied to hold flour for dusting.
8. Select desired belt/roller speed. Speed will vary with product type and user experience. It is recommended to start at a slower speed until machine experience and product knowledge is gained.
9. For sheeting, remove and store all carriages, pressure plates, and curling chains. The LVO Sheeter/Moulder is supplied with a pressure plate storage hanger and curling chain hooks. Sheeting will require several passes, starting with a larger roller gap and reducing every pass until desired thickness is reached. For pie and pizza crust, rotate dough by 180° on the second pass to give the dough a round shape.
10. A catch tray is provided to catch product as it leaves the carriage.

Bread Moulding

Remove excess flour dust from the conveyor belt when changing from various pressure plate sizes. Space is provided for storing pressure plates under the conveyor table when not in use. Position the bread moulding attachment slots to the conveyor table studs and slide the moulding carriage away from the sheeting head. Place the appropriate curling chain onto the front scraper hooks; light for buns and rolls, and heavy for larger bread products. Attach desired pressure plate to carriage and adjust dough guides to proper width (see General Operation instructions). You are now ready to begin bread moulding.



LVO Manufacturing, Inc.

808 N. 2nd Avenue E., P.O. Box 188

Rock Rapids, IA 51246

www.lvomfg.com

(712) 472-3734

1-800-346-5749

Fax (712) 472-2203

Piece the mixed dough into the desired sizes. Position the dough guides on the in-feed tray so the dough pieces travel down the middle of the conveyor belt to assure proper moulding.

To mould bread, place the dough pieces on the in-feed tray using the dough guides for positioning. It may be necessary to flatten the dough slightly to allow for smooth flow into the sheeting rollers. The dough will be sheeted through the rollers and will exit onto the conveyor belt. The sheeted dough pieces will be “curled” as it travels under the curling chain and the pressure plate will “mould” the product as it passes under the bread moulder attachment.

Due to the difference in nature of various doughs, it may be necessary to do some experimenting with the position of the pressure plate relative the conveyor belt. The correct setting is determined when the sheeted dough piece is moulded to the exact width of the pressure plate. When the correct setting is determined, it should be noted for future reference.

Dough Sheeting

When sheeting dough, regardless of the product being sheeted, the adjustment rollers should be set progressively. To obtain the desired thickness, several passes may be required. Before each pass, the roller setting should be reduced until desired thickness is achieved.

To obtain uniformity of the finished product, it is important that uniform pieces are prepared for feeding to the machine. The dough should be taken from the bowl in approximately 10 pound pieces, put on a bench and shaped into a rectangle. With the least amount of handling, the pieces should be shaped uniformly in length, width, and thickness, and should fit $\frac{2}{3}$ of the width and full length of a standard 18” x 26” baking sheet. Keep pieces as free from wrinkles as possible (let it have 20-30 minutes intermediate proof before feeding the machine).

Flour the in-feed tray and the top of the dough pieces. Place the pieces on the in-feed tray and flatten out some by hand, both width and length. Set dough guide on in-feed tray so that the dough will travel down the center of the conveyor table. Set the sheeting rollers so they progressively sheet to the desired thickness. As you gain experience and the machine becomes “broken in,” less flour dust will be needed and more uniform results will be obtained.



LVO Manufacturing, Inc.

808 N. 2nd Avenue E., P.O. Box 188

Rock Rapids, IA 51246

www.lvomfg.com

(712) 472-3734

1-800-346-5749 Fax (712) 472-2203

Operational Tips

The dough condition and type has a dramatic effect upon settings and satisfactory Sheeter/Moulder performance. Various problems and their solutions are listed below.

Problem	Correction
Dough Tearing	Increase gap between the dough rollers. The dough may need to rest before working. Reduce Belt Speed.
Too Many Crumbs	Decrease the pressure on the pressure plate.



LVO Manufacturing, Inc.

808 N. 2nd Avenue E., P.O. Box 188

Rock Rapids, IA 51246

www.lvomfg.com

(712) 472-3734

1-800-346-5749

Fax (712) 472-2203

Scheduled Maintenance



Always disconnect the power before servicing the machine.

Daily:

Remove and clean all scrapers:

Front Scraper Removal

1. Lift the spring handles off from the infeed chute.
2. Lift the scraper assembly off the scraper positioning rod.

Note: Reassemble in reverse order.

Rear Scraper Removal

1. Close the rollers.
2. Open the upper back cover.
3. Lift the spring handles off from the rear scraper.
4. Lift the scraper of the roller adjustment shaft.

Note: Reassemble in reverse order.

Conveyor Belt Tension and Location:

Inspect the belt for condition and location. Belt should be centered on the table. If the belt is closer to one side, tighten the adjustment nut on that side ¼ turn. Run the belt and observe for correct centering and adjust as required. Several adjustments may be required.

Belt Tightness – The conveyor belt needs to be tight enough to not slip when held by hand.

DO NOT OVER TIGHTEN THE BELT!!

The belt tension is adjusted by turning the adjustment nuts on both sides an equal amount.



CAUTION: BE SURE TO REINSTALL BOTH ROLLER FINGER GUARDS AFTER ALL ADJUSTMENTS HAVE BEEN MADE.

Monthly:

Drive Chain:

1. Lightly oil the drive chain
2. Inspect for loose or worn components
3. Repair or replace as needed



LVO Manufacturing, Inc.

808 N. 2nd Avenue E., P.O. Box 188

Rock Rapids, IA 51246

www.lvomfg.com

(712) 472-3734

1-800-346-5749

Fax (712) 472-2203

Cleaning Instructions

 **Always disconnect the power before cleaning the machine.**

At the end of each day's use, the operator of the machine must clean the machine according to the following procedure:

1. Remove all scrapers (see Scheduled Maintenance section) and pressure plates and clean in sink or washer.
2. Remove Moulding Carriage (if attached).
3. Clean all food contact surfaces of machine, i.e. rollers, infeed, belt.
 - a. Remove all excess flour and dough crumbs with dry cloth or brush.
 - b. Thoroughly clean all surfaces with hot water and soap/detergent and a clean cloth.
 - c. Rinse all surfaces with fresh warm water and a clean cloth. Do NOT reuse cloth from washing.
 - d. Mix a sanitizing solution of fresh warm water and chlorine bleach to a mixture of 1 teaspoon of bleach per gallon of water.
 - e. Wipe all food surfaces with sanitizing solution and a clean cloth. Do NOT reuse cloth from rinse. Keep cloth in the sanitizing solution when not in use.
 - f. Let all surfaces air dry.
 - g. In order to clean the entire surface of the rollers and belt, it may be necessary to run the machine for a short period of time to turn the roller/advance the belt. To do this, first replace all covers and reconnect power. Next start the machine until a new area is accessible for cleaning. Then re-disconnect the power, remove covers and continue cleaning.

 **CAUTION: DO NOT ATTEMPT TO CLEAN MACHINE WHILE RUNNING OR RUN WITHOUT ALL COVERS/SAFETY DEVICES IN PLACE.**

4. Clean food contact surfaces on the Moulding Carriage using same method as the machine.
5. Wipe down all other exposed surfaces of the machine with a clean cloth. This should be done before replacing scrapers and cover.



LVO Manufacturing, Inc.

808 N. 2nd Avenue E., P.O. Box 188

Rock Rapids, IA 51246

www.lvomfg.com

(712) 472-3734

1-800-346-5749

Fax (712) 472-2203

Replacement Parts List

SM20, SM24

Rollers & Scrapers

<u>Part Number</u>	<u>Description</u>
200-2042	20" Dough Roller Assembly – SM20
200-2043	24" Dough Roller Assembly – SM24
200-2023	20" Rear Belt Roller Assembly – SM20
200-2044	24" Rear Roller Assembly – SM24
200-6088	Front Belt Roller Tube – SM20
200-6089	Front Belt Roller Shaft – SM20
200-6123	Front Belt Roller Tube – SM24
200-6124	Front Belt Roller Shaft – SM24
200-6073	20" Scraper Blade
200-6117	24" Scraper Blade
200-2016	20" Rear Scraper Assembly
200-2017	20" Front Scraper Assembly
200-2041	24" Rear Scraper Assembly
200-2040	24" Front Scraper Assembly
200-6080	Front Scraper Tensioning Hook
200-6072	Rear Scraper Tensioning Hook
523-5001	Scraper Tensioning Spring

Pressure Plates

<u>Part Number</u>	<u>Description</u>
200-2001	6" Plate
200-2002	9" Plate
200-2003	12" Plate
200-2032	14" Plate
200-2004	16" Plate
200-2034	18" Plate
200-2031	20" Plate – SM24 Only
200-2039	22" Plate – SM24 Only
200-2009	Bolillo Plate



LVO Manufacturing, Inc.

808 N. 2nd Avenue E., P.O. Box 188

Rock Rapids, IA 51246

www.lvomfg.com

(712) 472-3734

1-800-346-5749 Fax (712) 472-2203

Miscellaneous Parts

<u>Part Number</u>	<u>Description</u>
200-2025	Light Curling Chain
200-2026	Heavy Curling Chain
200-6065	Catch Tray – SM20
200-6114	Catch Tray – SM24
200-6048	In-feed Guide
200-6009	Moulding Carriage Dough Guide – L/H
200-6010	Moulding Carriage Dough Guide – R/H
200-2006	Moulding Carriage – SM20
200-2010	Moulding Carriage – SM24
200-6064	Front Belt Roller Finger Guard
200-6177	Roller & Moulding Carriage Handle
200-6176	Moulding Carriage Hub
200-6178	Moulding Carriage Adjustment Rack
523-5003	Moulding Carriage Handle Spring
200-6182	Roller Adjustment Hub
200-6179	Roller Adjustment Rack
523-5009	Roller Adjustment Handle Spring
519-5020	Adjustment Handle Pin – Carriage & Roller
524-5001	Knob – Moulding Carriage
527-5001	Flour Tray
517-5010	Caster

Electrical Parts

<u>Part Number</u>	<u>Description</u>
512-5013	¾ HP DC Motor – 90 VDC
512-5018	Motor w/Gearbox – 90 VDC
511-5246	DC Speed Control
511-5247	Speed Potentiometer
511-5205	NO Contact Block
511-5107L	On/Off Station – Left Side
511-5107R	On/Off Station – Right Side
511-5105	Miniature Limit Switch
511-5286	Rear Cover Safety Switch Sensor
511-5287	Rear Cover Safety Switch Magnet



LVO Manufacturing, Inc.

808 N. 2nd Avenue E., P.O. Box 188

Rock Rapids, IA 51246

www.lvomfg.com

(712) 472-3734

1-800-346-5749

Fax (712) 472-2203

Drive Parts

<u>Part Number</u>	<u>Description</u>
525-5007	Idler Sprocket
200-2053	Idler Base & Shaft
525-5010	Chain Tensioner
525-5024	32 Tooth Spur Gear – Roller Adjustment
525-5021	Roller Adjustment Bearing (with Flange)
200-6136	84 Tooth Eccentric Spur Gear
525-5025	$\frac{3}{4}$ " Eccentric Spur Gear Bearing
525-5003	$\frac{3}{4}$ " Cam-Lock Bearing – Stationary Dough Roller
525-5004	Stamped Bearing Flangette – Stationary Dough Roller
525-5015	19 Tooth Sprocket – Dough Rollers
525-5013	13 Tooth Sprocket – Rear Belt Roller
525-5003	$\frac{3}{4}$ " Cam-Lock Bearing – Rear Belt Roller
525-5004	Stamped Bearing Flangette – Rear Belt Roller
525-5012	12 Tooth Sprocket – Motor
525-5036	Front Belt Roller Bearing (no Flange)
200-6045	Drive Chain

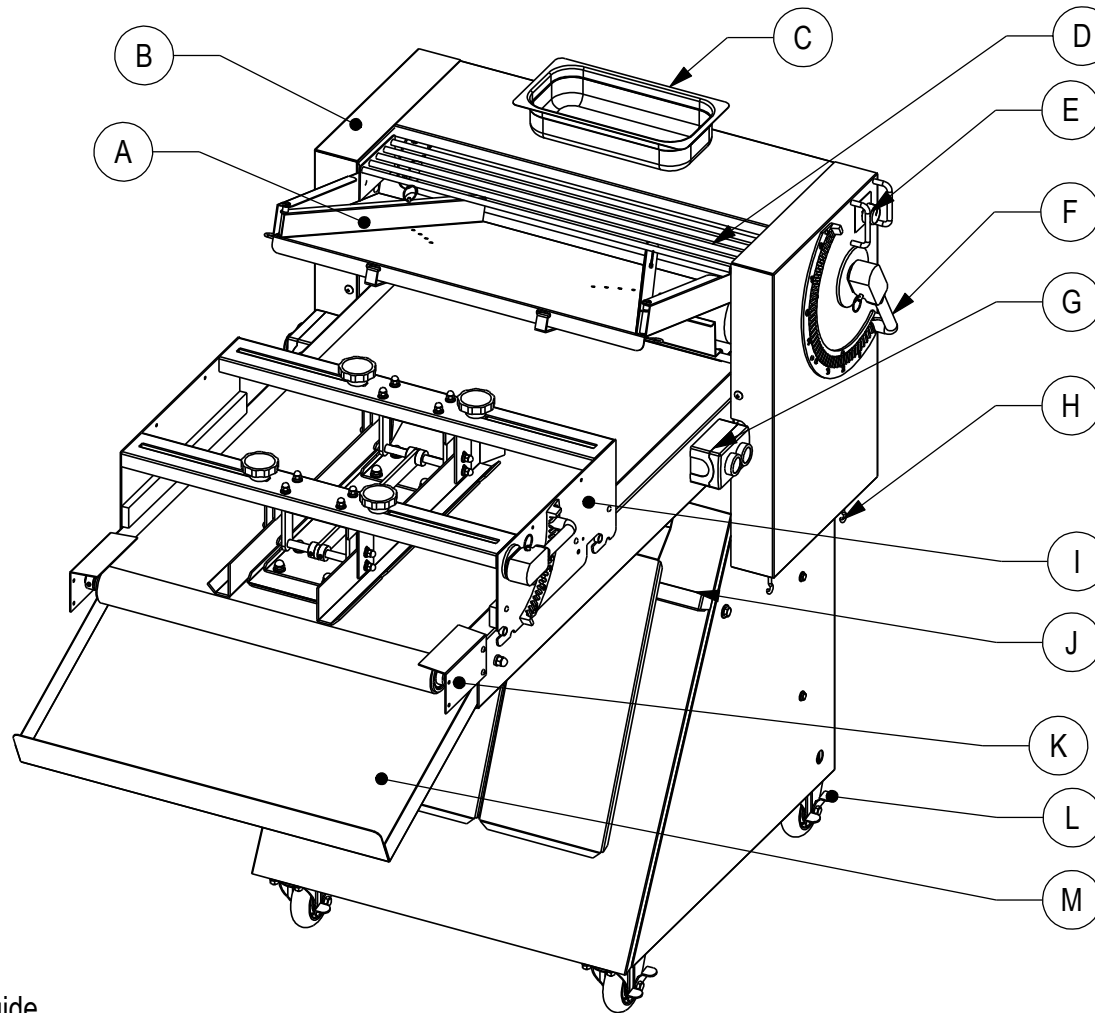

- A. Dough Guide
- B. Chain Guard Cover
- C. Flour Tray
- D. Dough Roller Safety Guard
- E. Speed Control Knob
- F. Roller Adjustment Handle
- G. Start/Stop Station
- H. Curling Chain Storage Hook
- I. Moulding Carriage
- J. Pressure Plate Storage Hanger
- K. Front Belt Roller Finger Guard
- L. Casters
- M. Catch Tray



LVO Manufacturing, Inc
 808 N 2nd Ave E
 Rock Rapids, IA 561246
 Phone: (712) 472-3734

Mat. -	Scale 1:12	Name: General View
Ga. -	Finish -	SM20 & SM24
Rev. -	9/7/2010 C. Wiowood	No. 200-1004-7

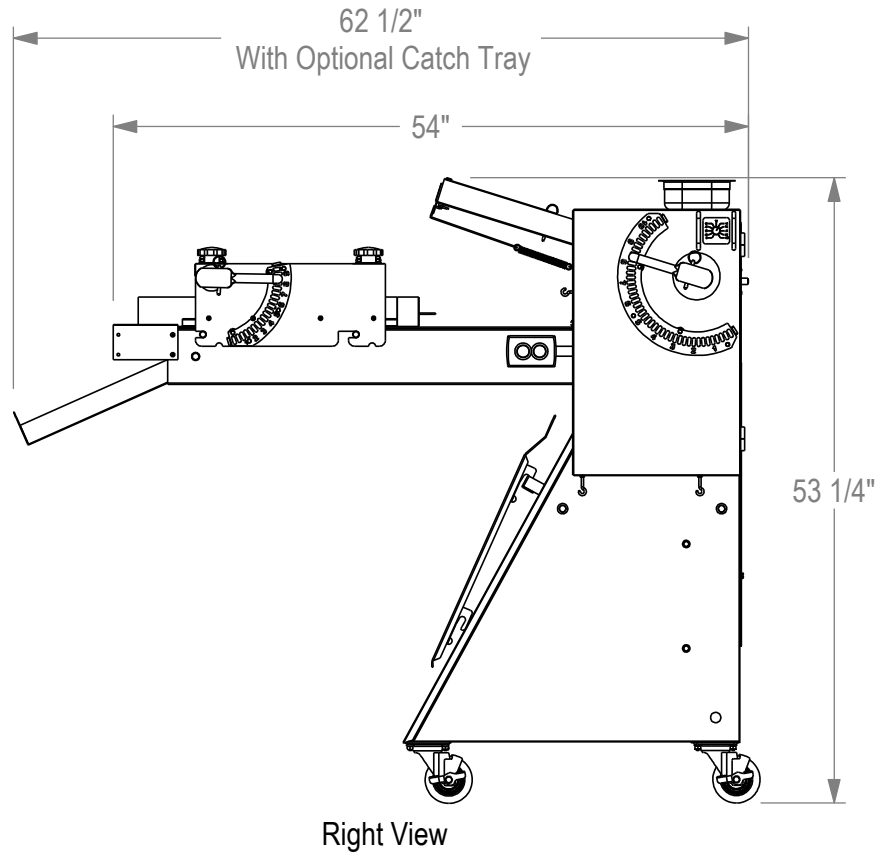
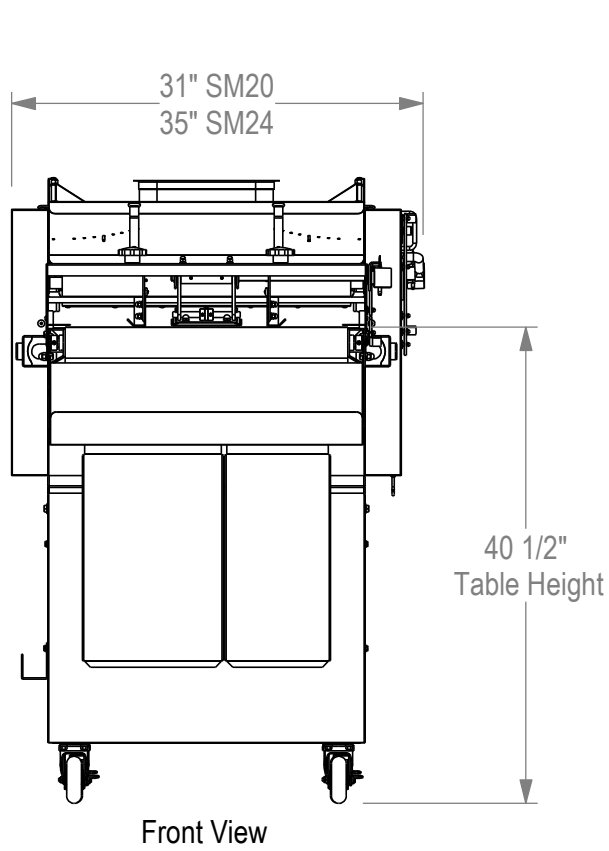

LVO Manufacturing, Inc
 808 N 2nd Ave E
 Rock Rapids, IA 561246
 Phone: (712) 472-3734

Mat. -	
Ga. -	Finish -
Rev. -	

Scale 1:16
9/7/2010
C. Wiowood

Name: SM20/SM24
Informative
No. 200-1004-1

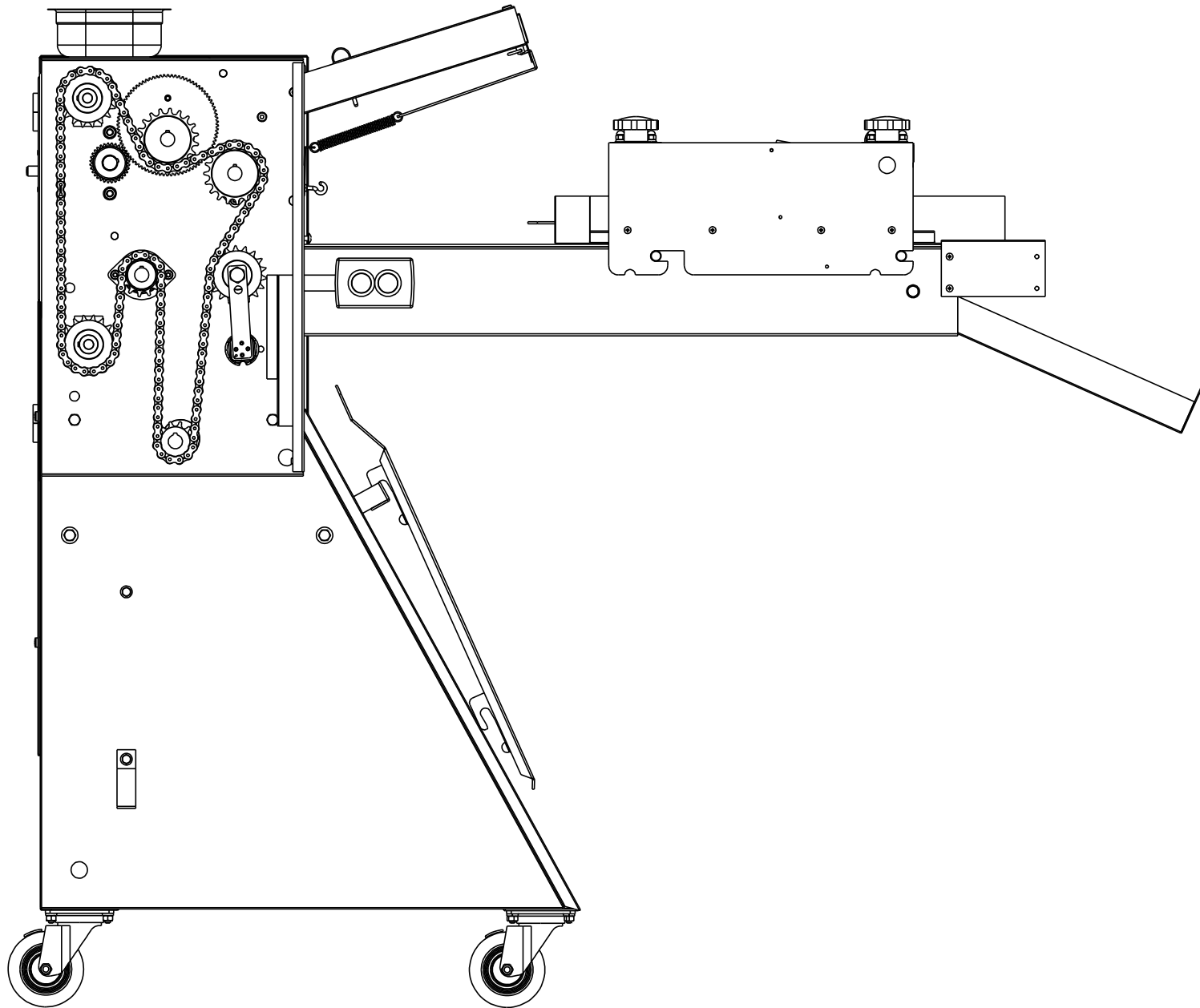

LVO Manufacturing, Inc
 808 N 2nd Ave E
 Rock Rapids, IA 561246
 Phone: (712) 472-3734

Mat. -	
Ga. -	Finish -
Rev. -	

Scale 1:8
9/8/2010
C. Wiowood

Name: Left View
cover removed
No. 200-1004-3

NOTE
USE 16 GA. WIRE

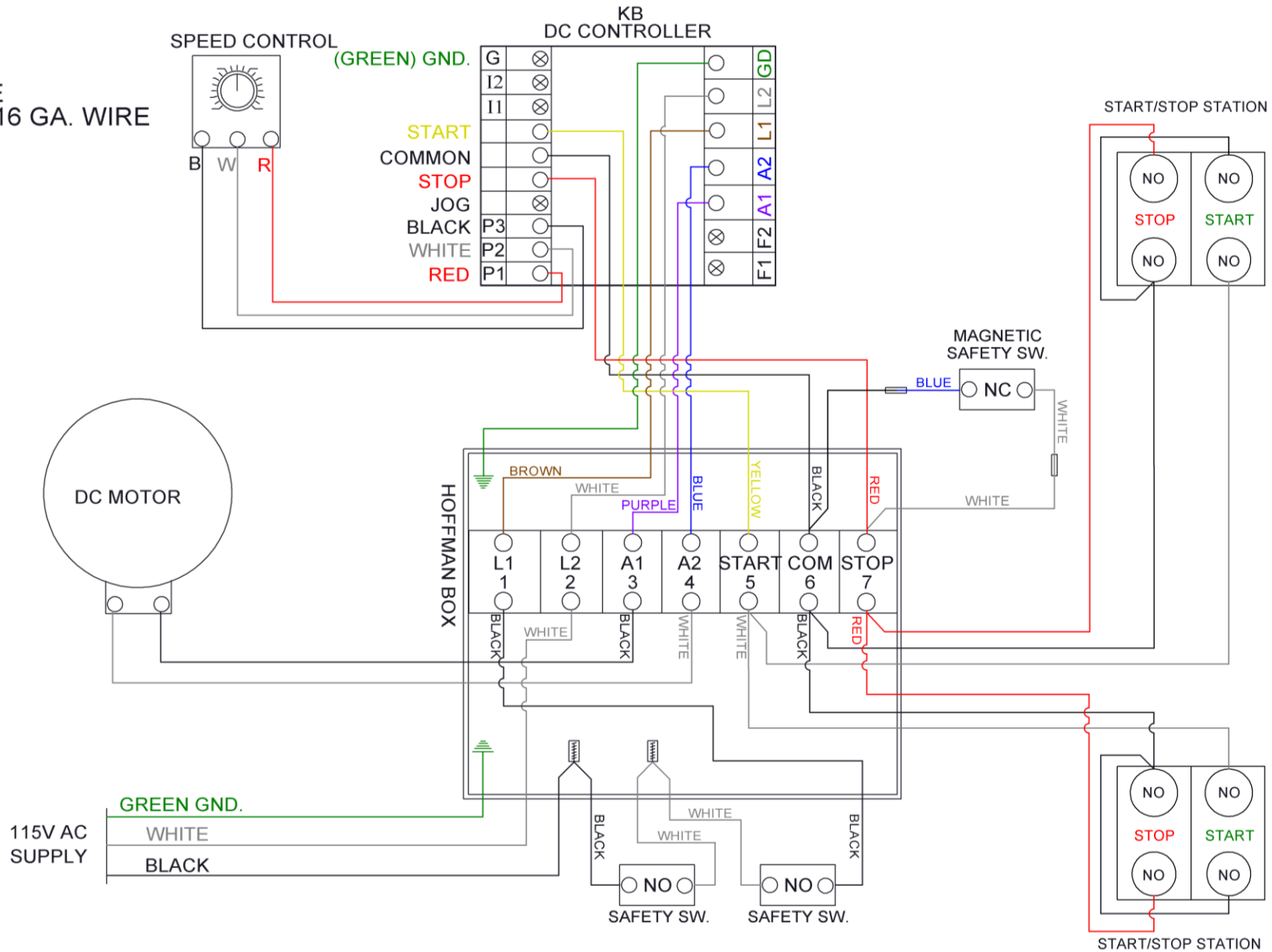

LVO Manufacturing, Inc
808 N 2nd Ave E
Rock Rapids, IA 51246
Phone: (712) 472-3734

Mat. -	
Ga. -	Finish -
Rev. -	

Scale 1:1
12/13/2011
C. Woivood

Name: S/M Schematic
-
No. 122-1030KB1-MAG