

ITEM	DESCRIPTION	MODEL(S)	PART # (208V/230V)	PART # (460V)
A	PUMP BREAKER	FL10, PT10, CL10	511-5344	511-5342
		FL14, PT14	511-5346	511-5343
B	WASH HEATER BREAKER		511-5347	511-5343
C	RINSE HEATER BREAKER			
D	PUMP CONTACTOR	FL10, PT10, CL10	511-5294	511-5292
		FL14, PT14	511-5295	511-5293
E	WASH HEAT CONTACTOR		511-5294	
F	RINSE HEAT CONTACTOR			
G	PUMP OVERLOAD	FL10, PT10, CL10	511-5305	511-5303
		FL14, PT14	511-5307	511-5304
H	FAN SPEED CONTROL		511-5256	
I	TRANSFORMER		511-5056	
J	PRIMARY FUSE		511-5130	511-5045
K	115V SECONDARY FUSE		511-5074	
L	24V SECONDARY FUSE		511-5207	
M	LOGIC CONTROL		511-5314	

Logic Control Inputs	
I1	Float
I2	Door Switch
I3	Stop Button
I4	Start Button
I5	Light Wash
I6	Medium Wash
I7	Heavy Wash
I8	Fill Button
Logic Control Outputs	
Q1	Fill Solenoid
Q2	Wash Light
Q3	Pump
Q4	Rinse Solenoid
Q5	Fan
Q6	Low Speed Fan
Q8	LWCO

Lower Terminal Blocks			
Soap	To 24VAC Soap Dispenser	1	To Float
Fan	To Exhaust Fan	W	From Wash High Limit
T3 & T4	To Rinse Solenoid	R	From Rinse High Limit
4	From Float	C & H	To Temp Controls
T1	To Door Switch		
T2	From Door Switch		
Fill	To Fill Solenoid		
-	-		

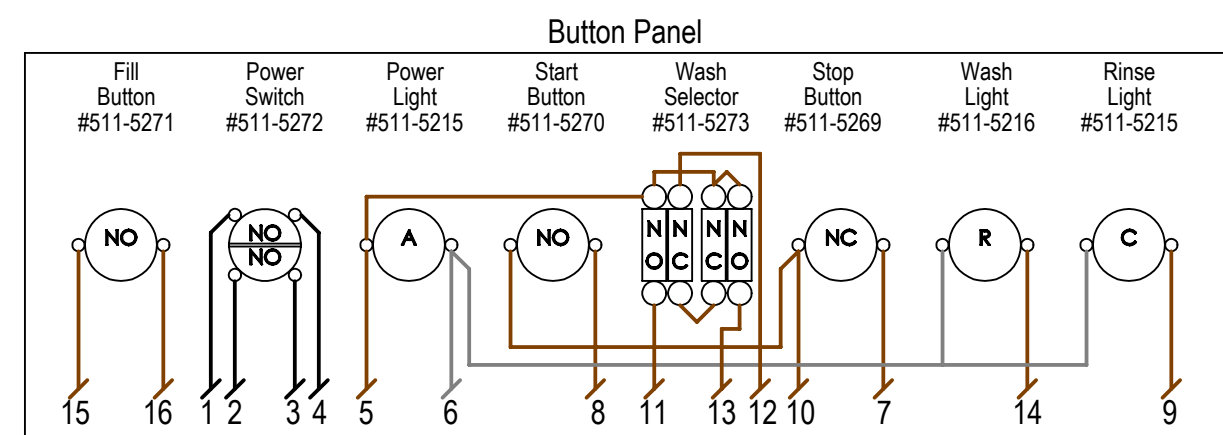

Line	24VAC	115VAC
Common		

Fuse Table	
208V/230V Primary	3 Amp
460V Primary	2 Amp
115V Secondary	1.25 Amp
24V Secondary	10 Amp

Name: 10, 14, & 25 Pan Schematic - Electric Heat

LVO Manufacturing, Inc
808 N 2nd Ave E
Rock Rapids, IA 561246
Phone: (712) 472-3734

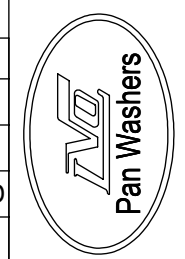

No. 124-1101A

Rev. -

C. Woodward

12/29/2014