

Logic Control Input	
I1	Float
I2	Door Switch
I3	Stop Button
I4	Start Button
I5	Light Wash
I6	Medium Wash
I7	Heavy Wash
I8	Fill Button
Logic Control Outputs	
Q1	Fill Solenoid
Q2	Wash Light
Q3	Pump
Q4	Rinse Solenoid
Q5	Fan
Q8	LWCO

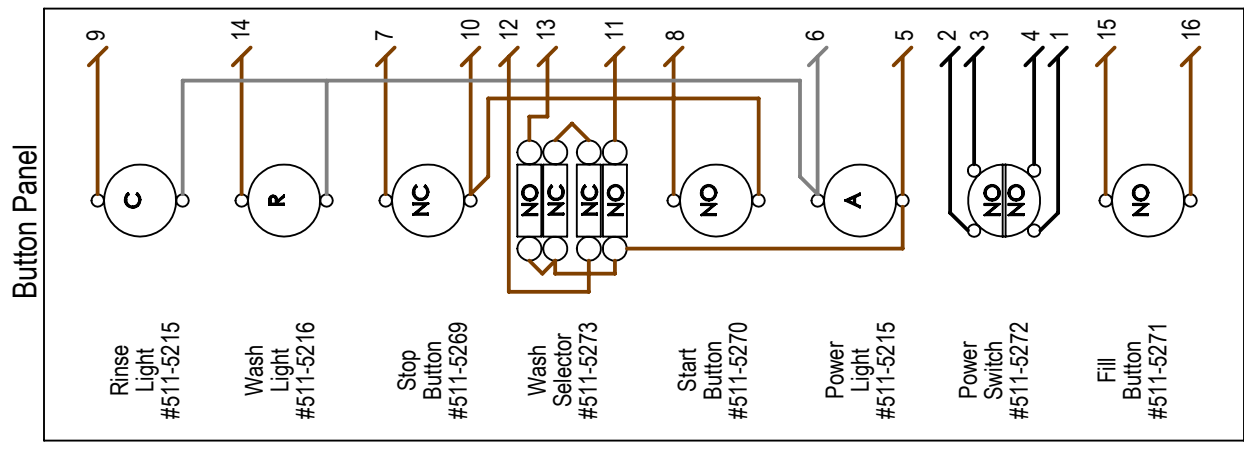

Upper Terminal Blocks			
-	-	C & H	To Temp Controls
Fill	To Fill Solenoid	T1	To Door Switch
T3 & T4	To Rinse Solenoid	T2	From Door Switch

Lower Terminal Blocks			
Soap	To 24VAC Soap Dispenser	W	From Wash High Limit
4	From Float	R	From Rinse High Limit
1	To Float	-	-

Fuse Table	
208V/230V Primary	3 Amp
460V Primary	2 Amp
24V Secondary	12 Amp

ITEM	DESCRIPTION	PART # (208V/230V)	PART # (460V)
A	FAN OVERLOAD	511-5300	
B	FAN CONTACTOR	511-5290	
C	TRANSFORMER	511-5056	
D	24V SECONDARY FUSE	511-5181	
E	LOGIC CONTROL	511-5314	
F	PRIMARY FUSE	511-5130	511-5045
G	PUMP BREAKER	511-5348	511-5344
H	WASH HEAT BREAKER		
I	WASH HEAT BREAKER	511-5347	511-5343
J	RINSE HEAT BREAKER		
K	RINSE HEAT BREAKER		
L	FAN BREAKER	511-5340	
M	PUMP CONTACTOR	511-5297	511-5294
N	WASH HEAT CONTACTOR		
O	WASH HEAT CONTACTOR	511-5294	
P	RINSE HEAT CONTACTOR		
Q	RINSE HEAT CONTACTOR		
R	PUMP OVERLOAD	511-5308	511-5305

Name: FL36 Schematic - Electric Heat

LVO Manufacturing, Inc
808 N 2nd Ave E
Rock Rapids, IA 561246
Phone: (712) 472-3734

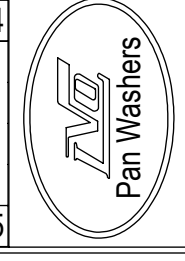

Rev. -

1/14/2015 C. Woodward